



CORRINGHAM

DAMEN ASD TUG 3211

GENERAL

Classification	Bureau Veritas I✕HULL✕MACH Fire-fighting Escort Tug - Unrestricted Navigation
Flag	British
Owner	Targe Towing Limited
Builder	Damen
Built	2005
Fire-Fighting	Full FiFi 1 (2400 m3/hr)

DIMENSIONS

Length overall	32.24m
Beam overall	11.70m
Max Draught	5.3m
Gross tonnage	374t

PERFORMANCE

Bollard pull	70t
Max Speed	13 kn

PROPULSION SYSTEM

Main engines	MAK 6M25C
Total power	3952kw (5300bhp) at 1800rpm
Azimuth thrusters	CP Rollsroyce Aquamaster US 255/3500

TANK CAPACITIES

Fuel Oil	168.00 m3
Lub Oil	1.50 m3
Fresh Water	57.00 m3
Foam	10.00 m3

AUXILIARY EQUIPMENT

Generator sets	CAT 3004b T x 2 (95KW each)
----------------	-----------------------------

DECK EQUIPMENT

Fore Winch	DMT Twin Heavy Duty 175T
Tow Hook	100t Mampaey towing hook
Capstan	2 x 1 ton Capstan
Crane	Palfinger PK48000MC - 2.2t at 15.80m

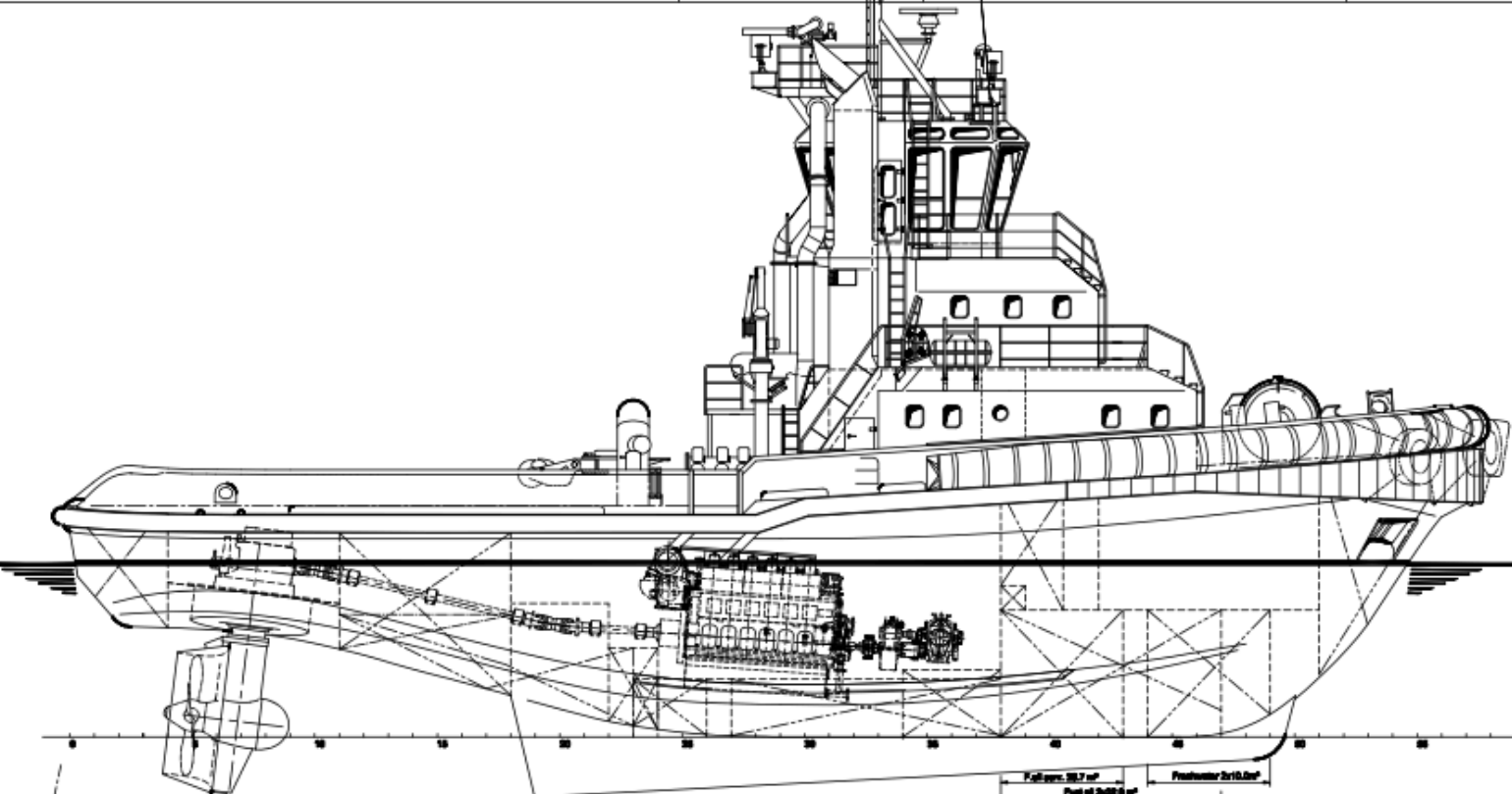

Maindeck

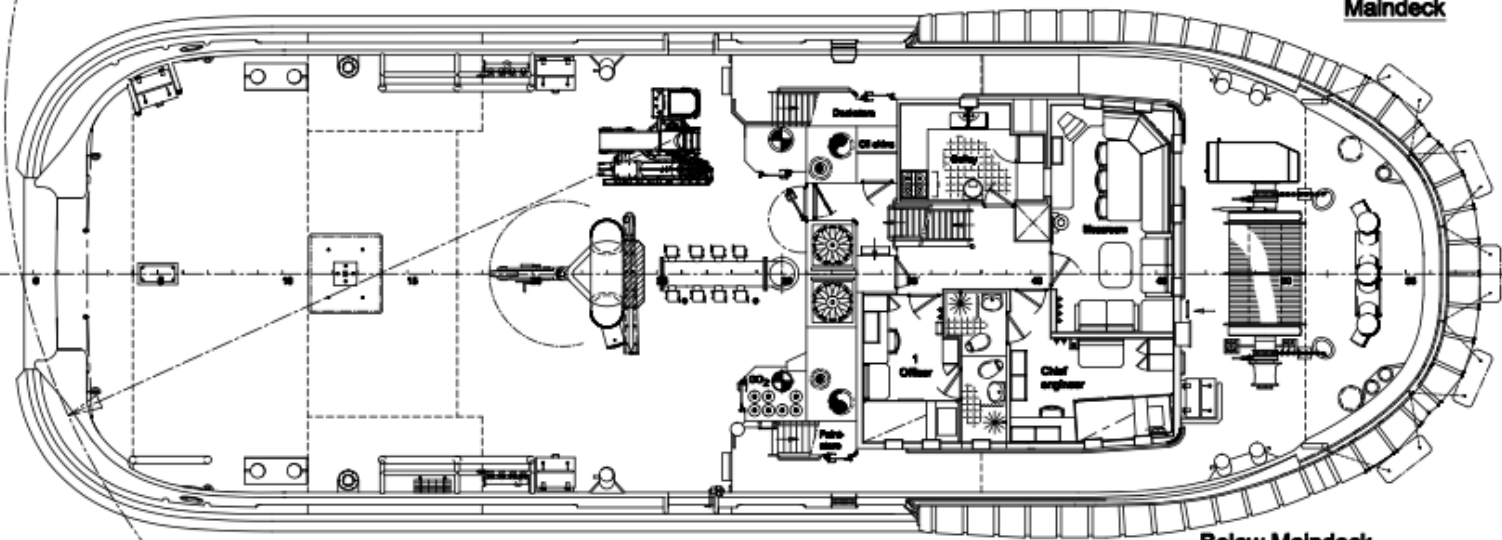

Below Maindeck

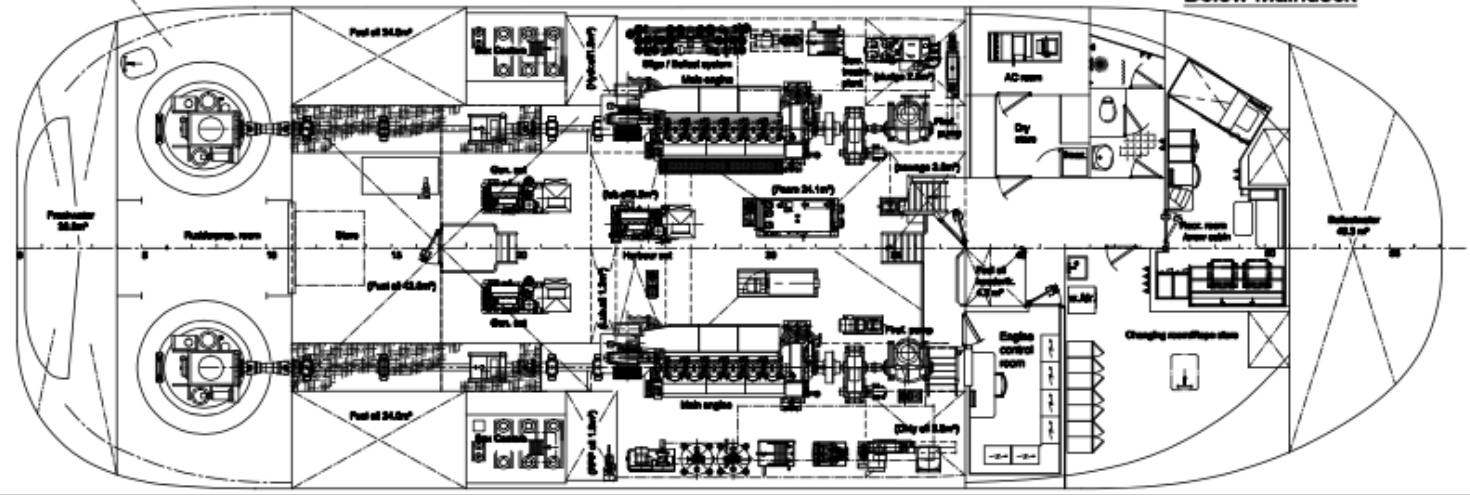

Scale : 0/10-200-201-0.000 / Plate : 04-10-200/10114



Bridgedeck

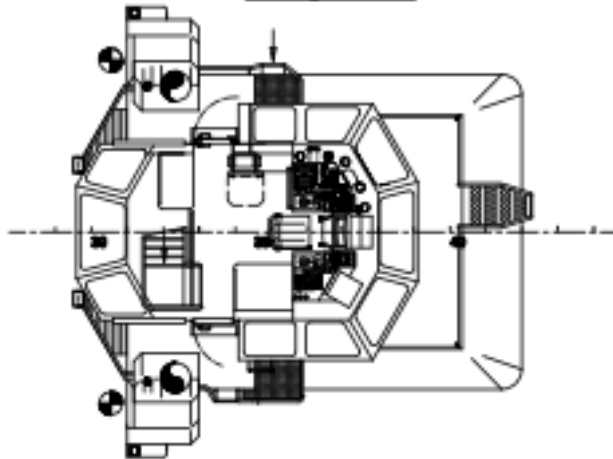

Topdeck

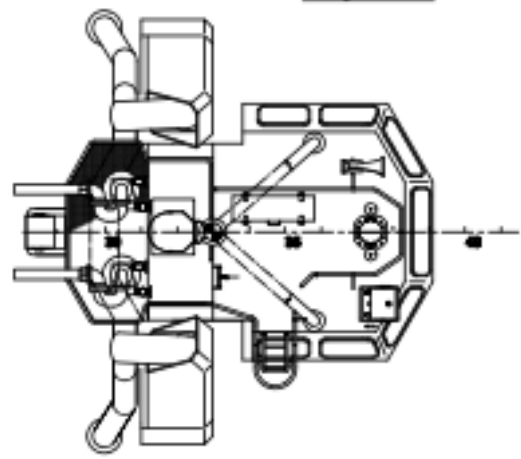

**Damen
ASD Tug 3211**



Boatdeck

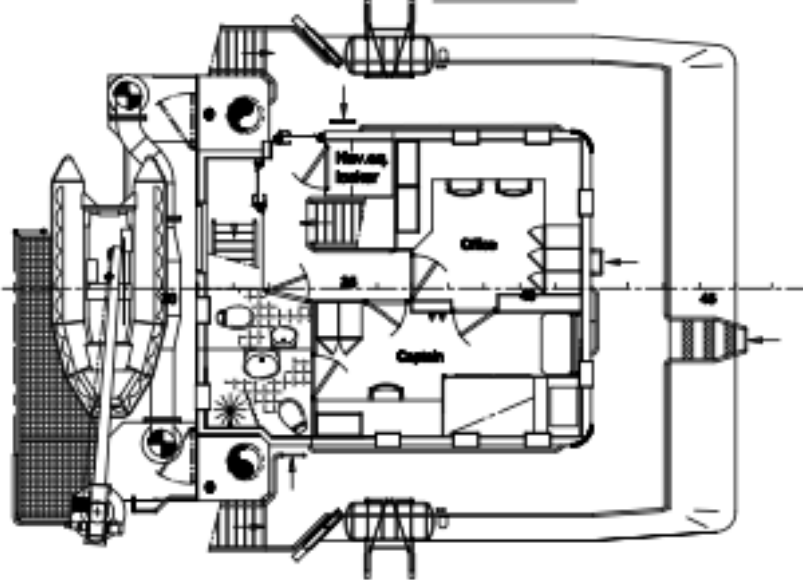

Principal dimensions:

Length o.a.	32.22 m
Beam o.a.	11.70 m
Depth at sides	5.00 m
Draught aft (approx.)	5.30 m

<p>The information and data contained herein are proprietary to Damen Shipyards and are not to be copied, reproduced, duplicated or disclosed to others, in whole or in part without prior written consent of Damen Shipyards.</p>			
no.	date	name	project / other subject
B	08-12-2004	RdL	FB Arrangement aftdeck updated
A	21-04-2004	RdL	FB General updated
<p>DAMEN DAMEN SHIPYARDS SCHIEDAM</p> <p>1317 BA Schiedam 3211 NL Schiedam P.O. Box 111 3200 AB Schiedam</p>			
<p>General arrangement plan</p>			
designed by	R. de Lamer		ship no. ASD Tug 3211
checked by	FB		project no. 511210
date	12-12-2003 AD	scale	1:50
sheet no.	5		total n. sheets
ACAD 5			ship no. 511210-000-001

